

FEATURES

- ❖ Powered by an Intel N5105 processor.
- ❖ Triple Extended displays with two 4K HDMI and 1 VGA output.
- ❖ Featuring Two 3.0 USB ports and Two 2.0 USB Ports.
- ❖ 2.4/5GHz is the fastest built-in Wi-Fi.
- ❖ Built-in Bluetooth 4.2 support.
- ❖ Delivering equivalent performance with a small and appropriate design.
- ❖ Quiet operation and cooling system while using only one-tenth the power of a typical desktop PC.
- ❖ Alpha pro supports a wide range of peripherals.
- ❖ Alpha Pro comes with Built-in Kensington Lock Port.
- ❖ 8GB DDR4 2666MHz RAM.
- ❖ 128GB M.2 NVMe SSD.
- ❖ Featured with Intel UHD Graphics.
- ❖ support video conferencing on all platforms.
- ❖ Compatible with Citrix and VMware.
- ❖ Vesa Mount Kit.

Powerful And Affordable Computing Solution

Alpha Pro is a compact and portable computer that provides high-performance computing solutions without compromising on performance. These devices are designed to be smaller in size compared to traditional desktop computers, making them ideal for space-constrained environments or individuals who value portability.

Alpha Pro typically come with powerful processors, ample RAM, and storage options, allowing them to handle demanding tasks such as multimedia editing and productivity applications. They often offer a wide range of connectivity options, including USB ports, HDMI, and Wi-Fi, enabling you to connect peripherals and accessories easily.

Alpha Pro's compact size makes it suitable for environments with limited space, such as small offices, classrooms, or living rooms. They are also portable and easy to transport, allowing users to take their computing power wherever they go. Additionally, Alpha Pro consumes less power than larger desktop computers, making it energy-efficient and cost-effective.

Despite their smaller form factor, Alpha Pro can still have powerful hardware configurations, including multi-core processors, dedicated graphics cards, solid-state drives (SSDs), and a sufficient amount of RAM. Alpha Pro can be attached to the back of a monitor.

Broad USB Peripheral Support

Alpha Pro supports a broad variety of peripherals, including printers, scanners, smart card readers, web cameras, headphones, speakers, digital signatures, biometric fingerprint readers, mass fingerprint readers, mass storage devices, and others.

High-Speed Data Transfer

High-speed data transfer is a crucial requirement for many users, especially when dealing with large files or transferring data between devices. USB (Universal Serial Bus) ports are commonly used for data transfer, and USB 3.0 and USB 2.0 are two popular versions of this technology. Clientronix Alpha Pro Featuring Two 3.0 USB ports and Two 2.0 USB Ports, high-speed data transfer.

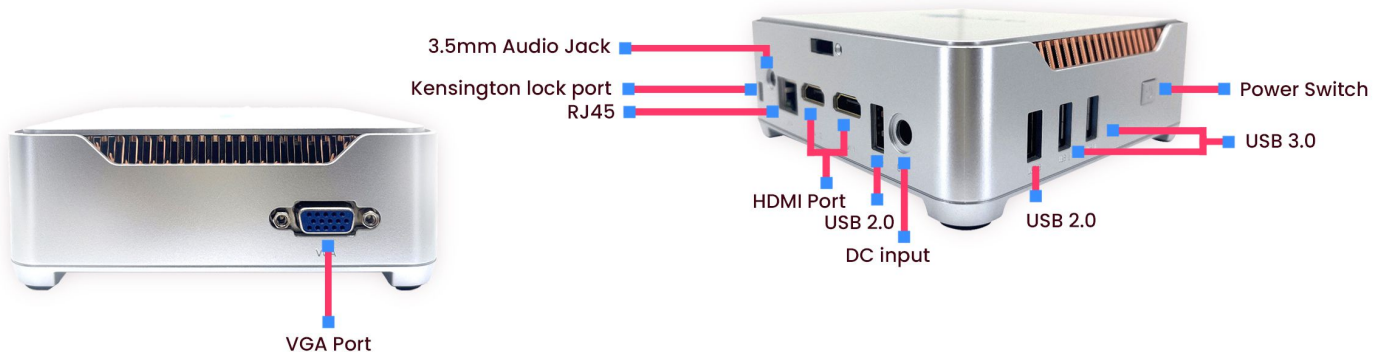

+91-9840434525
1800-8434-686



www.clientronix.in
info@clientronix.in



1A, New Colony, 2nd Street,
Pallikaranai,
Ch-600100 (Head Office)



2, Veerathamman Kovil Street,
Pallikaranai,
Ch-600100 (Warehouse)

TYPE	SPECIFICATION	DESCRIPTION
PROCESSOR	Model	Intel 11th Gen N5105 Processor
	Max Turbo Speed	2.90 GHz
MEMORY	Model	DDR4 [SODIMM]
	Capacity	8 GB / 16 GB
STORAGE	SSD	M.2 NVME / SATA SSD, Max upto 2 TB
	Additional Storage Slot	2.5" SATA, max upto 2 TB
TPM	CPU IntegratesTPM	Support TPM 2.0
TRIPLE SCREEN	Video Output	Tripple displays with 2 HDMI & 1 VGA Outputs.
LED	State	Blue Light-Switch on Red light-Machine dormancy [Sleep Mode]
WIRELESS	Model	RTL8821CE on Board
	Protocol	IEEE 802.11a, b/g, n, ac
BLUETOOTH	Model	RTL8821CE on Board
	Protocol	Support Bluetooth 4.2
HARDWARE PORTS	Ethernet	10/100/1000
	USB 2.0	2
	USB 3.0	2
	HDMI	2
	VGA	1
	Power Button	1
	DC In	5.5/2.1mm DC Jack x1
OPERATING SYSTEM	Audio Port	3.5mm Phone Jack x 1 [2 in 1 jack]
	Version	Windows & Linux Supported
ENVIRONMENT	Working temperature	0~40°C
	Memory temperature	-20~60°C
	Humidity	90% @ 40°C [No Condensation]
POWER SUPPLY	Input 100~240V 50/60Hz Output12V/2.5A DC 5.5*2.1mm [30W]	
PRODUCT	Dimension	130mm*130mm*45.5mm
	Case Material	Plastic
	Weight	Net Weight 386g, Gross Weight 757g
MOUNTING KIT	Yes	

*Alpha Pro comes with Standard 3 - years warranty for device and power adapter.



+91-9840434525
1800-8434-686



www.clientronix.in
info@clientronix.in



1A, New Colony, 2nd Street,
Pallikaranai,
Ch-600100 (Head Office)



2, Veerathamman Kovil Street,
Pallikaranai,
Ch-600100 (Warehouse)